

DIRECT CURRENT SOLENOIDS FOR HYDRAULICS type MR

- Fast and simple installation
- Reliable functioning in every position
- Long life span
- Solenoid screws into valve block
- Removable coil
- Corresponding to VDE 0580 recommendations
- Plug-in connector corresponding to EN 175301-8003 standards
- MR - 045 fulfil EMC (89/336/EEC)

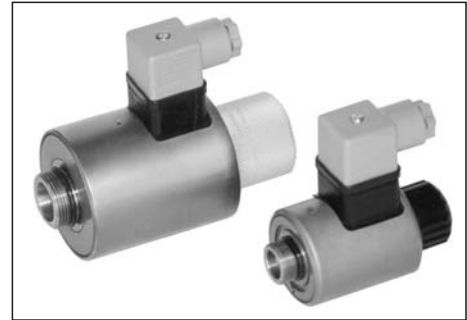

MR-060, MR-045

Description of operation

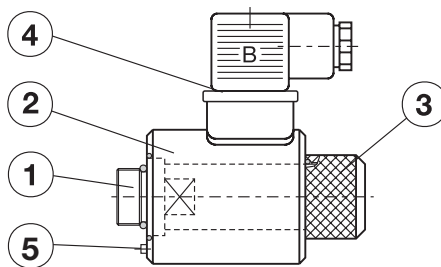

A piston that can move freely lengthwise, is placed in an oil-tight core (1). A coil (2) protected by housing surrounds the core. The plug-in connector (4) is fixed to the housing. The coil is fixed on the core by retaining nut (3) and protected against rotation with a pin (5).

This type of solenoid is used for controlling of directional control valves. They are activated by passing electric current through the solenoid's coil. For manually operation of the solenoid, there is the emergency switch at the back of the solenoid. Solenoids are of "push-design". When the solenoid is activated the piston pushes the piston rod out of it. The force with which the piston pushes at various points of its stroke (solenoid's movement) is given in the tables. The solenoids are designed for direct current. If a rectifier bridge is added, the alternating current can also be used. They are built for voltages of 12, 24, 48, 110 and 230V. Allowed deviation from the nominal voltage is within -10 to + 5%. Their intermittence is 100% at the ambient temperature of 40°C. When the ambient temperature is increased the intermittence is correspondingly lowered. If the buyer so wishes, solenoid for different voltages and intermittence can be delivered. Solenoids have the degree of protection of enclosures IP 65 (IEC). They are tested to the pressure of 210 bar. Their life span in normal working conditions is 10⁷ operations.

Ordering code

1. Core:

MR - * - J
 Size

Note: - For DC and AC voltage the same core is used.

2. Coil:

MR - * - O - *
 Size
 Supply voltage

3. Retaining nut:

MR - * - M - *
 Size
 Hand operation of solenoid

4. Plug-in connector:

MR - K - * - * - *
 Supply voltage
 Colour-signal lamp
 Cable gland

Example: MR-045-J, MR-045-O-12DC, MR-045-M, MR-K-24AC-L

Note: - Every part of the solenoid (position 1-4) has to be ordered separately.

Size

ø 45 mm = 045
 ø 62 mm = 060

Supply voltage

direct voltage	alternating voltage
24 V = no design.	12 V = 12 AC
12 V = 12 DC	24 V = 24 AC
48 V = 48 DC	48 V = 48 AC
110 V = 110 DC	110 V = 110 AC
230 V = 230 DC	230 V = 230 AC *

Hand operation of solenoid

without hand operation = no design
 with hand operation = G

Colour-signal lamp

grey - without signal lamp = A
 black - without signal lamp = B
 transparent - with signal lamp = L

Cable gland

Pg 9 = no design
 Pg 11 = 11

* see Note (next page)

Note:

* To fulfil EMC (89/336/EEC) a capacitor must be built in when using the solenoid with supply voltage 230 V, AC

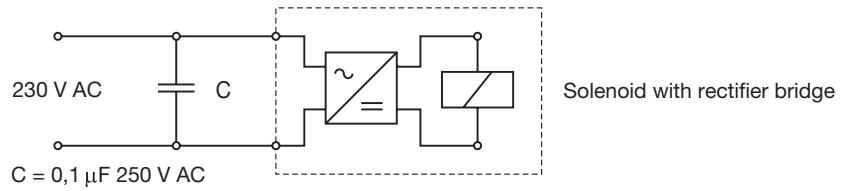

Technical data

Type of solenoid	Force F at 90% Un, and working temperature when ED is 100%										Power P	Pressure	Intermittence	Mass
	Stroke													
	0 mm	1 mm	2 mm	3 mm	4 mm	5,5 mm	6 mm	7 mm	8 mm	9 mm				
	N	N	N	N	N	N	N	N	N	N	W	bar	%	kg
MR-045	100	75 (70)	60 (50)	30 (20)	20 (10)	8 (5)	5 (3)				29*	210	100	0,6
MR-060	240	130	140	140	85	50	35	23	18	13	45	210	100	1,6

* - 12 V supply voltage - 36 W () - 230 V AC supply voltage

Dimensions (mm)

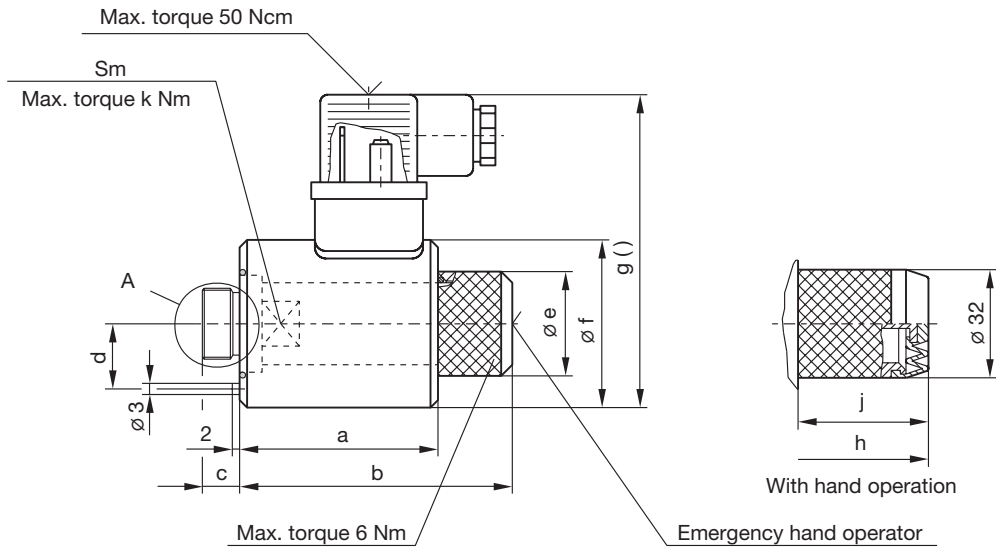

	a	b	c ^{±0,1}	d ^{+0,1}	∅e	∅f	g ()	h	j	k	Sm
MR-045	53	73	10	17,5	30	45	85 (91)	87	34	30	20
MR-060	72	107	11	23,9	40	62	103 (109)	122	50	50	27

() - AC supply voltage

A MR-045

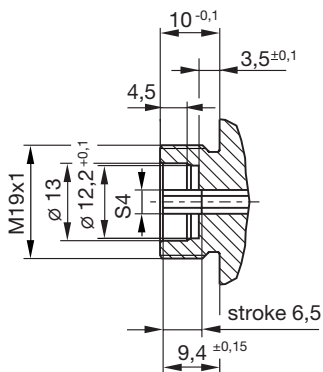

A MR-060

